

## FlexPAK 800 DX & FlexPAK 1000 DX

The leading extraction solution. Always the right capacity.



The FlexPAK Dx high vacuum unit is designed for the extraction of grinding dust, metal chips etc. FlexPAK Dx is also suitable for cleaning the workplace, the shop floor, and machines. The FlexPak Dx's controls allows it to regulate air flow to exact demand needed resulting in efficient operation and energy savings.

The system's filter cleaning process allows you to have longer filter life and ensures adequate air flow performance. The FlexPAK Dx has many options available such as waste bin level monitors, filter indicators and fire alarms to help keep your workplace safe and working efficient.

The FlexPAK Dx is the answer to multi-purpose dust control for on-tool extraction and work space housekeeping.

- Easy to install
- Built in Programmable Logic Control (PLC) functions
- Low running and maintenance costs
- Built in safety functions
- Suitable for a wide range of applications

Product name	FlexPAK 800 DX
Compressed air requirement	Dry and clean (Ø6 connection)
Installation	Indoor, Outdoor
Filter cleaning method	Reverse air pulse
Application	Dust, Granulate, Grit, Fumes, Chip
Working pressure (psi)	20
Dustbin volume (gal)	70
Max Airflow (cfm)	760
Filter Area (ft²)	700
Power Voltage (V)	460
Frequency (Hz)	60
No of phases	3
Filter type	Bag
Number of filter elements	1
Filter material	Anti-Static
Electric plug	Without
Working pressure (kPa)	20
Noise level (dB(A))	70
Capacity (max airflow m3/h)	470
Max vakuüm (in. wg)	141
Weight (lbs)	909
Power (Hp)	28.8 (21.5 Kw)

Product name	FlexPAK 1000 DX
Noise level (dB(A))	70
Compressed air requirement	Dry and clean (Ø6 connection)
Installation	Indoor, Outdoor
Filter cleaning method	Reverse air pulse
Application	Dust, Granulate, Grit, Fumes, Chip
Working pressure (psi)	15
Dustbin volume (gal)	70
Max Airflow (cfm)	760
Filter Area (ft²)	700
Power Voltage (V)	460
Frequency (Hz)	60
No of phases	3
Filter type	Bag
Number of filter elements	1
Filter material	Polyester
Electric plug	Without
Working pressure (kPa)	15
Noise level (dB(A))	70
Capacity (max airflow m3/h)	588
Max vakuüm (in. wg)	80
Weight (lbs)	909

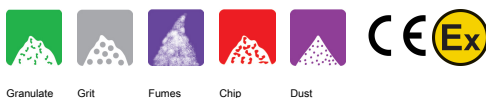

Granulate Grit Fumes Chip Dust

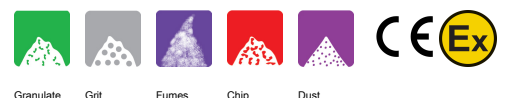

Granulate Grit Fumes Chip Dust

Model
40050312

Power (Hp)	Model
28.8 (21.5 Kw)	40050322
	40050352*
18,5	40050355**

\*IoT Ready  
\*\*IoT Ready - Advanced Sensors

## FlexPAK 800 DX

	Accessory	Part No
	Deflector 220x540	40376771
	Diff.pressure switch 3-15 kPa NC	40375273
	Bin Level Indicator (BLI) EX	40375269
	Fire alarm complete. Activated when the temperature exceeds +140 Deg. C. If placed in EX zone, intrinsic safe circuit is required.	40116540
	Flanged pipe Ø 150, 1 m	40375263*
	Flanged pipe d150, 0,5m	40376525*
	Flanged bend 90° Ø 150	40375264*
	Flanged bend 45° Ø 150	40376770*
	Silencer LT160	40139090
	Bend spiro BU 160mm 90dgr	40130810
	Grating spiro 160mm	40130230
	Plastic Bag 730x900, 20pcs, in conductive material for EX applications	40118800
	Flanged trans.pipe0,2m DN150 B-Flap	40376973
	Adapter flange/flange DN150 B-Flap	40376976
	Flexpak- Insight Perform	60200003
	Flexpak- Insight Perform Plus	60200004

*\*Pressure resistant pipes and bends for installation between filter inlet and the isolation valve. An adapter is needed between the pipe and isolation valve flanges. Fasteners and seals are included.*

## FlexPAK 800 DX

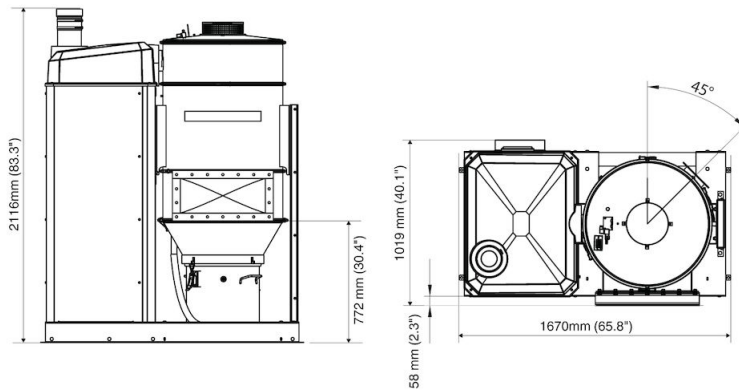
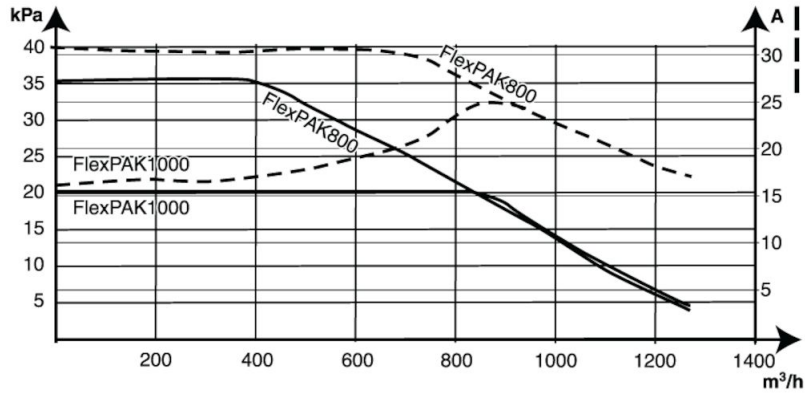

## FlexPAK 1000 DX

	Accessory	Part No
	Deflector 220x540	40376771
	Diff.pressure switch 3-15 kPa NC	40375273
	Bin Level Indicator (BLI) EX	40375269
	Fire alarm complete. Activated when the temperature exceeds +140 Deg. C. If placed in EX zone, intrinsic safe circuit is required.	40116540
	Flanged pipe Ø 150, 1 m	40375263*
	Flanged pipe d150, 0,5m	40376525*
	Flanged bend 90° Ø 150	40375264*
	Flanged bend 45° Ø 150	40376770*
	Silencer LT160	40139090
	Bend spiro BU 160mm 90dgr	40130810
	Grating spiro 160mm	40130230
	Plastic Bag 730x900, 20pcs, in conductive material for EX applications	40118800
	Flanged trans.pipe0,2m DN150 B-Flap	40376973
	Adapter flange/flange DN150 B-Flap	40376976
	Flexpak- Insight Perform	60200003
	Flexpak- Insight Perform Plus	60200004

*\*Pressure resistant pipes and bends for installation between filter inlet and the isolation valve. An adapter is needed between the pipe and isolation valve flanges. Fasteners and seals are included.*

## FlexPAK 1000 DX

