

Compact Palletizer

The Compact Solution for End of Line Palletizing!

The ROI Compact Palletizer is the answer for many end of line palletizing operations. With a small footprint in a pre-assembled package, the ROI Compact Palletizer is easy to set up, and quickly provides a return on your investment.

Palletizing operations for slow to moderate rate packaging lines are a problem for most companies. Repetitive motion injuries and training / re-training costs can eat away at productivity and profits.

Space constraints in existing facilities are also a challenge. Reconfiguring production lines for end of line automation is typically prohibitive or nearly impossible without major and costly changes.

The ROI Compact Palletizer may be the solution you have been looking for. The small size is easy to fit into existing tight spaces, typically not taking more space than what is currently being used for manual palletizing. AND, the system eliminates the ergonomic and repetitive motion issues of manual palletizing operations.



The base model allows for pallet jack loading and removal of pallets from the palletizer. A hinged door provide access to the side and a laser scanner us used to guard the pallet entrance / exit.

Multiple pallet patterns can be pre-programmed allowing quick production change overs.

Options and accessories are available to customize the system to fit your specific needs.

Contact us to discuss your palletizing and packaging challenges. ROI and our Sales Partners have expertise in palletizing, packaging solutions, and other automated material handling applications. We would be happy to provide assistance and demonstrate a positive Return on YOUR Investment (ROI).

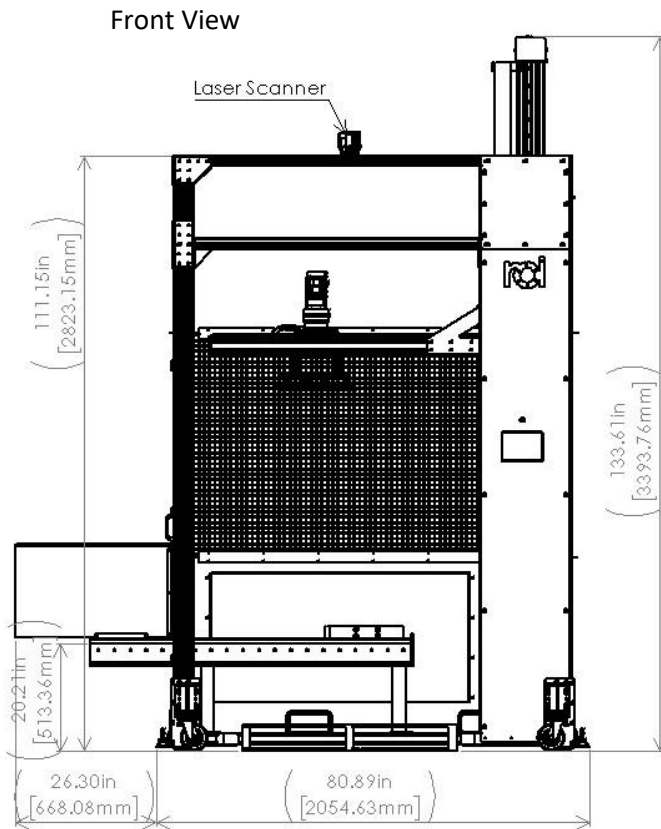

Model: CP100-8-L/20

Top view

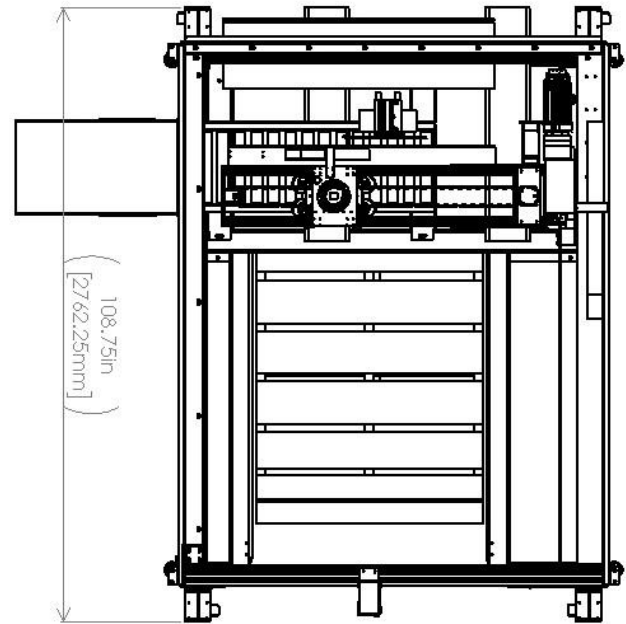

Patent #: 9,511,957

Features / Specifications:

Product weight capacity: 100 kg (220 lb)

Product type: Cartons, Bags, Pails, etc.

Palletizing Rate: Up to 8 picks per minute

Pallet Height:

Model CP100-8—up to 8' high (96")

Model CP100-5— up to 5' high (60")

Structure: Preassembled on casters for transport and positioning

Enclosure: 1" Wire mesh panels on 3 sides

Tooling: Single zone vacuum tool for cartons

Conveyor: Powered Roller conveyor, 72" long, inside palletizer

Safety: Integrated safety controls and access interlocks

Controls: Integrated control system with HMI interface to select pallet programs

Power: 230 VAC – 3p 26 amps or

460 VAC – 3p 14 amps

Compressed Air: 13-20 scfm @ 80 psi

Options / Accessories:

- Access doors in place of laser scanner
- Pallet dispenser with infeed / outfeed conveyor
- Tier sheet dispenser
- Automated discharge of completed pallet
- Infeed accumulation conveyor
- Tool Changer (manual)
- Custom EOAT (end of arm tooling)
- Annual service agreement / to include all parts and service for life of palletizer